



Tree Survey

At

Northcliff Lodge Penarth

Inspected by:-

Julian Wilkes BSc.For, MSc.Land Man, MIC.For, MArborA

Treescene Ltd

The Walled Garden

Old Coedarhydyglyn

St Nicholas

Cardiff

CF5 6SG

Tel No. 029 20599300

8th June, 2015

**Registered Office: Treescene Limited
The Walled Garden, Old Coedarhydyglyn, St. Nicholas, Cardiff CF5 6SG
Tel. 029 205 99300 Email. trees@treescene.co.uk**

I have been instructed by Celtic Developments Penarth Ltd to carry out a survey on trees at Northcliff Lodge, Penarth.

Scope of Report

This Tree Survey has been undertaken within the recommendations of British Standards 5837:2012 and current good arboricultural practice.

The survey entailed a visual inspection from ground level of all trees.

Each tree has been numbered and, where instructed, for future identification on site, have been tagged using small durable metal or plastic tags.

Due to variations of existing ground levels through the site, height dimensions are estimated and are given in metres. Accurate heights, measured with the aid of optical instruments can be provided where instructed.

Trunk/stem diameters are measured at 1.5 metres above ground level, or immediately above the root flare for multi-stemmed trees.

Estimate branch spread is taken in metres from the centre of the trunk, at the four cardinal points of a compass, to achieve an accurate representation of crown shape.

An assessment of a tree's age classification is made in terms of its maturity within the site's landscape.

An assessment of a tree's physiological condition is to be made as good, fair, poor, dead.

Data on the structural condition of the tree should be entered, e.g., collapsing, leaning and the presence of any decay or physical defect should be noted.

Preliminary management recommendations include further investigation of suspected defects that require more detailed assessment and potential for wildlife habitat.

An assessment of a tree's future life expectancy is made as <10, 10-20, 20-40 or >40 etc.

Table 1 – Cascade chart for tree quality assessment

Category and definition	Criteria (including subcategories where appropriate)		
<p><u>Category U</u> Those in such a condition that they cannot realistically be retained as living trees in the context of the current land use for longer than 10 years</p>	<ul style="list-style-type: none"> • Trees that have a serious, irremediable, structural defect, such that their early loss is expected due to collapse, including those that will become unviable after removal of other U category trees (i.e. where, for whatever reason, the loss of companion shelter cannot be mitigated by pruning) • Trees that are dead or are showing signs of significant, immediate, and irreversible overall decline • Trees infected with pathogens of significance to the health and/or safety of other trees nearby, or very low quality trees suppressing adjacent trees of better quality <p>NOTE Category U trees can have existing or potential conservation value which it might be desirable to preserve; see 4.5.7</p>		
	1 Mainly Arboricultural values	2 Mainly landscape values	3 Mainly cultural values, including conservation
<p><u>Category A</u> Those of high quality with an estimated remaining life expectancy of at least 40 years</p>	Trees that are particularly good examples of their species, especially if rare or unusual, or essential components of groups, or of formal or semi-formal arboricultural features (e.g. the dominant and/or principal trees within an avenue)	Trees, groups or woodlands of particular visual importance as Arboricultural and/or landscape features	Trees, groups or woodlands of significant conservation; historical, commemorative or other value (e.g. veteran trees or wood-pasture)
<p><u>Category B</u> Those of moderate quality with an estimated remaining life expectancy of at least 20 years</p>	Trees that might be included in category A, but are downgraded because of impaired condition (e.g. presence of significant though remediable defects, including unsympathetic past management and storm damage), such that they are unlikely to be suitable for retention for beyond 40 years; or trees lacking the special quality necessary to merit the category A designation	Trees present in numbers, usually growing as groups or woodlands, such that they attract a higher collective rating than they might as individuals; or trees occurring as collectives but situated so as to make little visual contribution to the wider locality	Trees with material conservation or other cultural benefits
<p><u>Category C</u> Those of low quality with an estimated remaining life expectancy of at least 10 years, or young trees with a stem diameter below 150mm</p>	Unremarkable trees of very limited merit or such impaired condition that they do not qualify in higher categories	Trees present in groups or woodlands, but without this conferring on them significantly greater collective landscape value, and/or trees offering low or only temporary/transient landscape benefits	Trees with no material conservation or other cultural value

T1	Sycamore (<i>Acer pseudoplatanus</i>)
Height	18m
Single/Multi stemmed	Multi stemmed
Stem Diameter	1.2m
Branch Spread	N – 10m E – 10m S – 10m W – 10m
Height of Crown	5m
Age	Mature
Physiological Condition	Fair
Structural Condition	Twin stemmed specimen of good form. Evidence of slight thinning in upper crown.
Prel. Man. Recommendations	No action required at this time
Est. Remaining Contribution	>40
Category	B2
T2	Ash (<i>Fraxinus excelsior</i>)
Height	13m
Single/Multi stemmed	Single stem
Stem Diameter	0.57m
Branch Spread	N – 6m E – 6m S – 6m W – 6m
Height of Crown	2m
Age	Middle aged
Physiological Condition	Fair to poor
Structural Condition	Tree of variable form with evidence of excessive thinning throughout crown
Prel. Man. Recommendations	Monitor for health
Est. Remaining Contribution	10-20
Category	C
T3	Oak (<i>Quercus robur</i>)
Height	4m
Single/Multi stemmed	Single stem
Stem Diameter	0.1m
Branch Spread	N – 1m E – 1m S – 1m W – 1m
Height of Crown	2m
Age	Young
Physiological Condition	Good
Structural Condition	Young tree of good form
Prel. Man. Recommendations	No action required at this time
Est. Remaining Contribution	>40
Category	C

T4	Lime (<i>Tilia europaea</i>)
Height	12m
Single/Multi stemmed	Single stem
Stem Diameter	0.49m
Branch Spread	N – 6m E – 6m S – 6m W – 6m
Height of Crown	2m
Age	Middle aged
Physiological Condition	Fair to poor
Structural Condition	Tree of variable form. Main stem leans slightly to east. Main stem divides at 2m leading to triple stemmed mid crown with evidence of minor inclusions within these lower forks. Evidence of minor root damage resulting from grass cutting machinery.
Prel. Man. Recommendations	Monitor for health
Est. Remaining Contribution	20-40
Category	C
T5	Sycamore (<i>Acer pseudoplatanus</i>)
Height	17m
Single/Multi stemmed	Multi stemmed
Stem Diameter	0.8m
Branch Spread	N – 6m E – 3m S – 6m W – 8m
Height of Crown	4m
Age	Mature
Physiological Condition	Poor
Structural Condition	Tree of poor form previously suppressed by a removed specimen. Main stem heavily colonised by ivy thus preventing full inspection. Evidence of basal decay and cracking of bark which indicates that this specimen is in a declining structural condition.
Prel. Man. Recommendations	Remove
Est. Remaining Contribution	<10
Category	U

T6	Sycamore (Acer pseudoplatanus)
Height	17m
Single/Multi stemmed	Single stem
Stem Diameter	0.34m
Branch Spread	N – 3m E – 1m S – 5m W – 2m
Height of Crown	4m
Age	Middle aged
Physiological Condition	Fair to poor
Structural Condition	Tree of variable form heavily suppressed by adjacent specimens. Tree with low stem diameter to height ratio.
Prel. Man. Recommendations	Monitor for stability
Est. Remaining Contribution	10-20
Category	C
T7	Sycamore (Acer pseudoplatanus)
Height	16m
Single/Multi stemmed	Single stem
Stem Diameter	0.26m
Branch Spread	N – 0m E – 2m S – 5m W – 3m
Height of Crown	4m
Age	Middle aged
Physiological Condition	Fair to poor
Structural Condition	Tree of variable form with crown more heavily developed on southern side. Dense vegetation prevents full inspection. Tree of low stem diameter to height ratio.
Prel. Man. Recommendations	Monitor for stability
Est. Remaining Contribution	10-20
Category	C

T8	Sycamore (<i>Acer pseudoplatanus</i>)
Height	16m
Single/Multi stemmed	Single stem
Stem Diameter	0.55m
Branch Spread	N – 6m E – 3m S – 7m W – 6m
Height of Crown	3m
Age	Middle aged
Physiological Condition	Fair to poor
Structural Condition	Tree of variable form. Main stem divides at 3m leading to twin stemmed mid crown. Evidence of possible decay associated at this lower fork. Some deadwood extending over adjacent footway.
Prel. Man. Recommendations	Prune to remove major deadwood. Monitor for health.
Est. Remaining Contribution	10-20
Category	C
G9	Group of Yew (<i>Taxus baccata</i>)
Height	5m
Single/Multi stemmed	Single and multi stemmed
Stem Diameter	Up to 0.3m
Branch Spread	N – 1m E – 1m S – 1m W – 1m
Height of Crown	0m
Age	Middle aged
Physiological Condition	Fair to poor
Structural Condition	Gappy hedgerow with some evidence of die-back in upper crowns
Prel. Man. Recommendations	Trim annual growth from top and sides
Est. Remaining Contribution	20-40
Category	C
T10	Beech (<i>Fagus sylvatica</i>)
Height	10m
Single/Multi stemmed	Multi stemmed
Stem Diameter	0.4m
Branch Spread	N – 6m E – 3m S – 0m W – 3m
Height of Crown	2m
Age	Middle aged
Physiological Condition	Poor
Structural Condition	Twin stemmed specimen of poor form with evidence of basal inclusion which may ultimately lead to failure. This specimen is heavily suppressed and unsuitable for retention.
Prel. Man. Recommendations	Remove
Est. Remaining Contribution	<10
Category	U

T11	Sycamore (Acer pseudoplatanus)
Height	15m
Single/Multi stemmed	Single stem
Stem Diameter	0.41m
Branch Spread	N – 5m E – 3m S – 3m W – 4m
Height of Crown	4m
Age	Middle aged
Physiological Condition	Fair to poor
Structural Condition	Tree of variable form. Some evidence of die-back and thinning of crown. Peeling and cracking of bark on main stem.
Prel. Man. Recommendations	Prune to remove major deadwood. Monitor for health.
Est. Remaining Contribution	10-20
Category	C

T12	Sycamore (Acer pseudoplatanus)
Height	13m
Single/Multi stemmed	Single stem
Stem Diameter	0.44m
Branch Spread	N – 4m E – 4m S – 8m W – 4m
Height of Crown	2m
Age	Middle aged
Physiological Condition	Poor
Structural Condition	Misshapen specimen of poor form. Evidence of basal decay with associated bulging at base of main stem indicates that this specimen is unsafe for retention adjacent to highway.
Prel. Man. Recommendations	Remove
Est. Remaining Contribution	<10
Category	U

T13	Corsican Pine (<i>Pinus nigra maritima</i>)
Height	17m
Single/Multi stemmed	Single stem
Stem Diameter	0.69m
Branch Spread	N – 5m E – 7m S – 10m W – 8m
Height of Crown	8m
Age	Mature
Physiological Condition	Fair
Structural Condition	Notable specimen of variable form. Main stem leans slightly to the south. Crown more heavily developed on southern side. Evidence of slight thinning and die-back in upper crown which is normal for a specimen of this age.
Prel. Man. Recommendations	Monitor for health
Est. Remaining Contribution	20-40
Category	B
G14	Group of Ash (<i>Fraxinus excelsior</i>)
Height	13m
Single/Multi stemmed	Single and multi stemmed
Stem Diameter	0.3m
Branch Spread	N – 3m E – 3m S – 3m W – 3m
Height of Crown	2m
Age	Middle aged
Physiological Condition	Poor
Structural Condition	Self-sown specimens of poor form leaning extensively. These trees will become a hazard in relation to the adjacent highway.
Prel. Man. Recommendations	Remove
Est. Remaining Contribution	<10
Category	U
T15	Ash (<i>Fraxinus excelsior</i>)
Height	14m
Single/Multi stemmed	Single stem
Stem Diameter	0.38
Branch Spread	N – 7m E – 5m S – 1m W – 5m
Height of Crown	4m
Age	Middle aged
Physiological Condition	Fair to poor
Structural Condition	Tree of variable form with evidence of slight thinning in upper crown
Prel. Man. Recommendations	Monitor for health
Est. Remaining Contribution	10-20
Category	C

T16	Norway Maple (<i>Acer platanoides</i>)
Height	9m
Single/Multi stemmed	Single stem
Stem Diameter	0.21m
Branch Spread	N – 2m E – 4m S – 2m W – 0m
Height of Crown	3m
Age	Young
Physiological Condition	Poor
Structural Condition	Tree of poor form with evidence of wound on main stem at 1.5m
Prel. Man. Recommendations	Remove
Est. Remaining Contribution	<10
Category	U
T17	Hawthorn (<i>Crataegus monogyna</i>)
Height	5m
Single/Multi stemmed	Multi stemmed
Stem Diameter	0.2m
Branch Spread	N – 3m E – 2m S – 3m W – 2m
Height of Crown	2m
Age	Middle aged
Physiological Condition	Fair to poor
Structural Condition	Twin stemmed specimen of variable form
Prel. Man. Recommendations	No action required at this time
Est. Remaining Contribution	10-20
Category	C
T18	Yew (<i>Taxus baccata</i>)
Height	7m
Single/Multi stemmed	Single stem
Stem Diameter	0.17m
Branch Spread	N – 2m E – 2m S – 2m W – 2m
Height of Crown	1m
Age	Middle aged
Physiological Condition	Fair to poor
Structural Condition	Tree of reasonable form with evidence of slight thinning of crown
Prel. Man. Recommendations	No action required at this time
Est. Remaining Contribution	20-40
Category	C

T19	Sycamore (<i>Acer pseudoplatanus</i>)
Height	18m
Single/Multi stemmed	Single stem
Stem Diameter	0.78m
Branch Spread	N – 3m E – 6m S – 10m W – 3m
Height of Crown	6m
Age	Mature
Physiological Condition	Fair to poor
Structural Condition	Tree of variable form. Main stem divides at 2m leading to twin stemmed mid crown. Evidence of thinning and die-back in crown. Major deadwood and hung-up branches extend over highway. Minor basal decay present. This specimen appears to be in a declining condition.
Prel. Man. Recommendations	Undertake 25% overall crown reduction. Prune to remove major deadwood. Monitor for health.
Est. Remaining Contribution Category	10-20 C
T20	Lime (<i>Tilia europaea</i>)
Height	14m
Single/Multi stemmed	Single stem
Stem Diameter	0.35m
Branch Spread	N – 4m E – 5m S – 3m W – 5m
Height of Crown	2m
Age	Middle aged
Physiological Condition	Fair to poor
Structural Condition	Tree of variable form which appears to have lost its leading shoot causing dysfunctional growth in upper crown
Prel. Man. Recommendations	Monitor for health
Est. Remaining Contribution Category	10-20 C

T21	Purple Plum (<i>Prunus pissardii</i>)
Height	10m
Single/Multi stemmed	Multi stemmed
Stem Diameter	0.4m
Branch Spread	N – 11m E – 4m S – 0m W – 0m
Height of Crown	1m
Age	Mature
Physiological Condition	Poor
Structural Condition	Tree of poor form leaning at an acute angle due to suppression by adjacent specimens. This tree is liable to failure.
Prel. Man. Recommendations	Remove
Est. Remaining Contribution	<10
Category	U

T22	Beech (<i>Fagus sylvatica</i>)
Height	11m
Single/Multi stemmed	Single stem
Stem Diameter	0.36m
Branch Spread	N – 4m E – 5m S – 3m W – 3m
Height of Crown	2m
Age	Middle aged
Physiological Condition	Fair to poor
Structural Condition	Tree of variable form. Main stem divides at 2m leading to twin stemmed mid crown with evidence of major inclusion within this lower fork. Ultimately this fork may fail.
Prel. Man. Recommendations	Monitor for safety
Est. Remaining Contribution	20-40
Category	C

G23	Group of Leyland Cypress (<i>Cupressocyparis leylandii</i>)
Height	14m
Single/Multi stemmed	Single and multi stemmed
Stem Diameter	0.25m
Branch Spread	N – 2m E – 2m S – 2m W – 2m
Height of Crown	0m
Age	Middle aged
Physiological Condition	Fair to poor
Structural Condition	Untidy hedgerow on boundary of site
Prel. Man. Recommendations	Trim annual growth from top and sides
Est. Remaining Contribution	10-20
Category	C

T24	Sycamore (Acer pseudoplatanus)
Height	14m
Single/Multi stemmed	Single stem
Stem Diameter	0.49m
Branch Spread	N – 6m E – 3m S – 4m W – 6m
Height of Crown	3m
Age	Mature
Physiological Condition	Fair to poor
Structural Condition	Tree of variable form with extensive squirrel damage throughout crown which has led to partial failure of some branches
Prel. Man. Recommendations	Prune to remove excessively squirrel damaged branches. Monitor for health.
Est. Remaining Contribution Category	10-20 C

G25	Group of Sycamore (Acer pseudoplatanus)
Height	14m
Single/Multi stemmed	Single stem
Stem Diameter	0.4m
Branch Spread	N – 6m E – 6m S – 6m W – 6m
Height of Crown	4m
Age	Middle aged
Physiological Condition	Fair to poor
Structural Condition	Trees generally of variable form with evidence of squirrel damage and associated decay at base of main stems. Ultimately these specimens may become unsafe.
Prel. Man. Recommendations	Monitor for safety
Est. Remaining Contribution Category	10-20 C

T26	Ash (<i>Fraxinus excelsior</i>)
Height	16m
Single/Multi stemmed	Single stem
Stem Diameter	0.4m
Branch Spread	N – 0m E – 7m S – 8m W – 0m
Height of Crown	6m
Age	Middle aged
Physiological Condition	Fair to poor
Structural Condition	Tree of variable form leaning at acute angle to the south-east. Evidence of dysfunctional tissue growth at base of main stem indicates that this specimen is under stress.
Prel. Man. Recommendations	Undertake 30% overall crown reduction. Monitor for health.
Est. Remaining Contribution	10-20
Category	C
T27	Holm Oak (<i>Quercus ilex</i>)
Height	16m
Single/Multi stemmed	Multi stemmed
Stem Diameter	0.8m
Branch Spread	N – 12m E – 1m S – 6m W – 12m
Height of Crown	3m
Age	Mature
Physiological Condition	Fair to poor
Structural Condition	Twin stemmed specimen with extensive basal decay
Prel. Man. Recommendations	Undertake 30% overall crown reduction. Monitor for safety.
Est. Remaining Contribution	10-20
Category	C
T28	Sycamore (<i>Acer pseudoplatanus</i>)
Height	10m
Single/Multi stemmed	Multi stemmed
Stem Diameter	0.4m
Branch Spread	N – 3m E – 3m S – 3m W – 3m
Height of Crown	2m
Age	Middle aged
Physiological Condition	Fair to poor
Structural Condition	Twin stemmed specimen of variable form with extensive squirrel damage throughout crown
Prel. Man. Recommendations	Monitor for safety
Est. Remaining Contribution	10-20
Category	C

T29	Sycamore (<i>Acer pseudoplatanus</i>)
Height	17m
Single/Multi stemmed	Multi stemmed
Stem Diameter	0.9m
Branch Spread	N – 8m E – 8m S – 8m W – 8m
Height of Crown	2m
Age	Middle aged
Physiological Condition	Fair to poor
Structural Condition	Multi stemmed specimen of variable form. Main stems heavily colonised by ivy thus preventing full inspection. Evidence of squirrel damage throughout crown. Evidence of severe basal inclusions which may ultimately lead to failure.
Prel. Man. Recommendations	Monitor for safety
Est. Remaining Contribution	10-20
Category	C
T30	Ash (<i>Fraxinus excelsior</i>)
Height	16m
Single/Multi stemmed	Multi stemmed
Stem Diameter	0.55m
Branch Spread	N – 3m E – 10m S – 3m W – 0m
Height of Crown	6m
Age	Middle aged
Physiological Condition	Poor
Structural Condition	Twin stemmed specimen of poor form. Major stem leans extensively to east over site and is at risk of failure.
Prel. Man. Recommendations	Remove
Est. Remaining Contribution	<10
Category	U
T31	Holm Oak (<i>Quercus ilex</i>)
Height	10m
Single/Multi stemmed	Single stem
Stem Diameter	0.32m
Branch Spread	N – 3m E – 3m S – 3m W – 3m
Height of Crown	1m
Age	Middle aged
Physiological Condition	Fair to poor
Structural Condition	Tree of variable form. Stem leans mainly to the north. Extensive ivy colonisation in upper crown.
Prel. Man. Recommendations	Sever ivy at base. Monitor for stability.
Est. Remaining Contribution	20-40
Category	C

T32	Monterey Cypress (<i>Cupressus macrocarpa</i>)
Height	19m
Single/Multi stemmed	Single stem
Stem Diameter	0.68m
Branch Spread	N – 3m E – 3m S – 3m W – 3m
Height of Crown	2m
Age	Middle aged
Physiological Condition	Fair to poor
Structural Condition	Tree of variable form. Main stem divides at 2m, 3m and 4m producing multi stemmed mid crown with evidence of inclusions within all lower forks. These forks may become at risk of failure at a later date.
Prel. Man. Recommendations	Monitor for safety
Est. Remaining Contribution	10-20
Category	C
G33	Group of Leyland Cypress (<i>Cupressocyparis leylandii</i>), Holly (<i>Ilex aquifolium</i>) and Sweet Bay (<i>Laurus nobilis</i>)
Height	10m
Single/Multi stemmed	Single and multi stemmed
Stem Diameter	0.4m
Branch Spread	N – 3m E – 3m S – 3m W – 3m
Height of Crown	1m
Age	Middle aged
Physiological Condition	Fair to poor
Structural Condition	Trees generally of variable form
Prel. Man. Recommendations	No action required at this time
Est. Remaining Contribution	10-20
Category	C
T34	Poplar (<i>Populus spp</i>)
Height	3m
Single/Multi stemmed	Single stem
Stem Diameter	0.1m
Branch Spread	N – 1m E – 1m S – 1m W – 1m
Height of Crown	1m
Age	Young
Physiological Condition	Poor
Structural Condition	Tree of poor form with extensive die-back throughout crown
Prel. Man. Recommendations	Remove
Est. Remaining Contribution	<10
Category	U

G35	Group of Leyland Cypress (<i>Cupressocyparis leylandii</i>) and Iris Yew (<i>Taxus baccata</i> 'Fastigiata')
Height	5m
Single/Multi stemmed	Multi stemmed
Stem Diameter	0.35m
Branch Spread	N – 1m E – 1m S – 1m W – 1m
Height of Crown	0m
Age	Middle aged
Physiological Condition	Fair to poor
Structural Condition	Trees generally of variable form. Some die-back in crowns.
Prel. Man. Recommendations	Monitor for health
Est. Remaining Contribution	10-20
Category	C
T36	Ash (<i>Fraxinus excelsior</i>)
Height	15m
Single/Multi stemmed	Single stem
Stem Diameter	0.33m
Branch Spread	N – 2m E – 3m S – 4m W – 3m
Height of Crown	3m
Age	Middle aged
Physiological Condition	Fair to poor
Structural Condition	Tree of variable form
Prel. Man. Recommendations	Monitor for health
Est. Remaining Contribution	10-20
Category	C
T37	Kilmarnock Willow (<i>Salix</i> spp)
Height	3m
Single/Multi stemmed	Single stem
Stem Diameter	0.1m
Branch Spread	N – 1m E – 1m S – 1m W – 1m
Height of Crown	1m
Age	Middle aged
Physiological Condition	Fair to poor
Structural Condition	Ornamental specimen of variable form
Prel. Man. Recommendations	No action required at this time
Est. Remaining Contribution	10-20
Category	C

T38	Grey Alder (<i>Alnus incana</i>)
Height	16m
Single/Multi stemmed	Multi stemmed
Stem Diameter	0.7m
Branch Spread	N – 4m E – 4m S – 4m W – 4m
Height of Crown	2m
Age	Middle aged
Physiological Condition	Fair to poor
Structural Condition	Twin stemmed specimen of variable form with evidence of basal inclusions
Prel. Man. Recommendations	Monitor for health
Est. Remaining Contribution	10-20
Category	C
T39	Ash (<i>Fraxinus excelsior</i>)
Height	13m
Single/Multi stemmed	Multi stemmed
Stem Diameter	0.4m
Branch Spread	N – 5m E – 5m S – 5m W – 5m
Height of Crown	2m
Age	Middle aged
Physiological Condition	Fair to poor
Structural Condition	Twin stemmed specimen of variable form with extensive basal inclusions
Prel. Man. Recommendations	Monitor for stability
Est. Remaining Contribution	10-20
Category	C
T40	Sycamore (<i>Acer pseudoplatanus</i>)
Height	18m
Single/Multi stemmed	Single stem
Stem Diameter	0.74m
Branch Spread	N – 8m E – 8m S – 8m W – 8m
Height of Crown	3m
Age	Mature
Physiological Condition	Fair
Structural Condition	Tree of reasonable form with well-balanced crown
Prel. Man. Recommendations	No action required at this time
Est. Remaining Contribution	>40
Category	B

T41	Sycamore (Acer pseudoplatanus)
Height	18m
Single/Multi stemmed	Single stem
Stem Diameter	0.44m
Branch Spread	N – 5m E – 2m S – 6m W – 3m
Height of Crown	3m
Age	Middle aged
Physiological Condition	Fair to poor
Structural Condition	Tree of reasonable form slightly suppressed by adjacent specimen
Prel. Man. Recommendations	No action required at this time
Est. Remaining Contribution	20-40
Category	C

T42	Sycamore (Acer pseudoplatanus)
Height	16m
Single/Multi stemmed	Multi stemmed
Stem Diameter	0.7m
Branch Spread	N – 7m E – 7m S – 7m W – 7m
Height of Crown	1m
Age	Mature
Physiological Condition	Fair to poor
Structural Condition	Multi stemmed specimen of variable form. Main stem and mid crown heavily colonised by ivy thus preventing full inspection. Extensive squirrel damage throughout crown which has led to some branch failure.
Prel. Man. Recommendations	Prune to remove excessively squirrel damaged branches. Sever ivy at base. Monitor for health.
Est. Remaining Contribution	20-40
Category	C

T43
Height 12m
Single/Multi stemmed Single stem
Stem Diameter 0.39m
Branch Spread N – 3m
E – 3m
S – 3m
W – 3m
Height of Crown 3m
Age Middle aged
Physiological Condition Fair to poor
Structural Condition Tree of variable form with extensive squirrel damage throughout crown. Main stem heavily colonised by ivy.
Prel. Man. Recommendations Prune to remove excessively squirrel damaged branches. Monitor for health.
Est. Remaining Contribution 10-20
Category C

T44
Height 18m
Single/Multi stemmed Single stem
Stem Diameter 0.78m
Branch Spread N – 8m
E – 5m
S – 7m
W – 6m
Height of Crown 5m
Age Mature
Physiological Condition Fair
Structural Condition Tree of reasonable form
Prel. Man. Recommendations Sever ivy at base. Prune to remove major deadwood.
Est. Remaining Contribution >40
Category B

T45
Height 18m
Single/Multi stemmed Single stem
Stem Diameter 0.55m
Branch Spread N – 6m
E – 2m
S – 6m
W – 5m
Height of Crown 3m
Age Middle aged
Physiological Condition Fair
Structural Condition Tree of reasonable form. Main stem heavily colonised by ivy thus preventing full inspection.
Prel. Man. Recommendations Sever ivy at base
Est. Remaining Contribution >40
Category B

T46	Sycamore (Acer pseudoplatanus)
Height	13m
Single/Multi stemmed	Single stem
Stem Diameter	0.7m
Branch Spread	N – 8m E – 9m S – 2m W – 3m
Height of Crown	4m
Age	Middle aged
Physiological Condition	Fair to poor
Structural Condition	Tree of variable form with crown more heavily developed on northern and eastern side. Main stem and mid crown heavily colonised by ivy thus preventing full inspection.
Prel. Man. Recommendations	Sever ivy at base. Monitor for health.
Est. Remaining Contribution	20-40
Category	C
T47	Sycamore (Acer pseudoplatanus)
Height	16m
Single/Multi stemmed	Single stem
Stem Diameter	0.6m
Branch Spread	N – 6m E – 3m S – 7m W – 6m
Height of Crown	3m
Age	Middle aged
Physiological Condition	Fair
Structural Condition	Tree of reasonable form. Main stem heavily colonised by ivy thus preventing full inspection.
Prel. Man. Recommendations	Sever ivy at base
Est. Remaining Contribution	20-40
Category	B
T48	Sycamore (Acer pseudoplatanus)
Height	14m
Single/Multi stemmed	Single stem
Stem Diameter	0.8m (estimate)
Branch Spread	N – 5m E – 5m S – 5m W – 5m
Height of Crown	4m
Age	Mature
Physiological Condition	Fair to poor
Structural Condition	Tree of variable form. Main stem densely colonised by ivy and other vegetation thus preventing full inspection. Evidence of slight die-back and thinning within crown.
Prel. Man. Recommendations	Sever ivy at base
Est. Remaining Contribution	10-20
Category	C

G49**Height****Single/Multi stemmed****Stem Diameter****Branch Spread****Height of Crown****Age****Physiological Condition****Structural Condition****Prel. Man. Recommendations****Est. Remaining Contribution****Category****Group of Sycamore (*Acer pseudoplatanus*) and Ash (*Fraxinus excelsior*)**

Up to 13m

Single and multi stemmed

Up to 0.35m

N – 3m

E – 3m

S – 3m

W – 3m

2m

Young/Middle aged

Fair to poor

Trees generally of variable form. Mainly coppice re-growth.

Monitor for health

10-20

C

T50**Height****Single/Multi stemmed****Stem Diameter****Branch Spread****Height of Crown****Age****Physiological Condition****Structural Condition****Prel. Man. Recommendations****Est. Remaining Contribution****Category****Yew (*Taxus baccata*)**

13m

Multi stemmed

0.8m

N – 5m

E – 5m

S – 5m

W – 5m

2m

Mature

Fair to poor

Tree of reasonable form but with evidence of severe thinning and die-back in upper crown

Monitor for health

20-40

C

T51**Height****Single/Multi stemmed****Stem Diameter****Branch Spread****Height of Crown****Age****Physiological Condition****Structural Condition****Prel. Man. Recommendations****Est. Remaining Contribution****Category****Corsican Pine (*Pinus nigra maritima*)**

17m

Single stem

0.77m

N – 8m

E – 8m

S – 8m

W – 8m

3m

Mature

Fair to poor

Tree of good form with extensive die-back and thinning throughout crown. This specimen appears to be in a declining condition.

Monitor for health

10-20

C

T52**Height****Single/Multi stemmed****Stem Diameter****Branch Spread****Height of Crown****Age****Physiological Condition****Structural Condition****Prel. Man. Recommendations****Est. Remaining Contribution****Category****Magnolia (Acuminata)**

3m

Multi stemmed

0.35m

N – 1m

E – 1m

S – 1m

W – 1m

0m

Middle aged

Poor

Tree of poor form. Heavily reduced in the past.

Remove

<10

U

T53**Height****Single/Multi stemmed****Stem Diameter****Branch Spread****Height of Crown****Age****Physiological Condition****Structural Condition****Prel. Man. Recommendations****Est. Remaining Contribution****Category****Magnolia (Acuminata)**

5m

Single stem

0.35m

N – 2m

E – 2m

S – 2m

W – 2m

1m

Mature

Fair to poor

Tree of variable form that has been heavily reduced in the past

No action required at this time

10-20

C

G54**Height****Single/Multi stemmed****Stem Diameter****Branch Spread****Height of Crown****Age****Physiological Condition****Structural Condition****Prel. Man. Recommendations****Est. Remaining Contribution****Category****Group of 1 Cherry (Prunus spp) and 1 Cypress (Cupressus spp)**

5m

Single stem

0.15m

N – 2m

E – 2m

S – 2m

W – 2m

1m

Young

Fair to poor

Trees of variable form

No action required at this time

10-20

C

T55	Ash (<i>Fraxinus excelsior</i>)
Height	16m
Single/Multi stemmed	Multi stemmed
Stem Diameter	0.7m
Branch Spread	N – 5m E – 8m S – 4m W – 4m
Height of Crown	2m
Age	Middle aged
Physiological Condition	Poor
Structural Condition	Twin stemmed self-sown specimen of poor form. Northern most stem leans excessively and is at risk of failure.
Prel. Man. Recommendations	Remove
Est. Remaining Contribution	<10
Category	U

T56	Sycamore (<i>Acer pseudoplatanus</i>)
Height	14m
Single/Multi stemmed	Single stem
Stem Diameter	0.45m
Branch Spread	N – 5m E – 5m S – 5m W – 5m
Height of Crown	3m
Age	Middle aged
Physiological Condition	Fair to poor
Structural Condition	Self-sown specimen of variable form
Prel. Man. Recommendations	Monitor for health
Est. Remaining Contribution	10-20
Category	C

G57	Group of Apple (<i>Malus</i> spp), Ash (<i>Fraxinus excelsior</i>), Rowan (<i>Sorbus aucuparia</i>), Cherry (<i>Prunus</i> spp) and Plum (<i>Prunus</i> spp)
Height	3m
Single/Multi stemmed	Single stem
Stem Diameter	0.1m
Branch Spread	N – 1m E – 1m S – 1m W – 1m
Height of Crown	0m
Age	Young
Physiological Condition	Fair to poor
Structural Condition	Mainly fruit trees of variable form
Prel. Man. Recommendations	No action required at this time
Est. Remaining Contribution	10-20
Category	C

G58

Group of Ash (*Fraxinus excelsior*) and Sycamore (*Acer pseudoplatanus*)

Height

17m

Single/Multi stemmed

Single and multi stemmed

Stem Diameter

Up to 0.7m

Branch Spread

N – 8m

E – 8m

S – 8m

W – 8m

Height of Crown

3m

Age

Mature

Physiological Condition

Fair/Fair to poor

Structural Condition

Trees surrounded by dense vegetation thus preventing full inspection. Trees generally of reasonable form but some specimens exhibit signs of mild die-back.

Prel. Man. Recommendations

Monitor for health

Est. Remaining Contribution

20-40

Category

C

T59

Lime (*Tilia europaea*)

Height

17m

Single/Multi stemmed

Multi stemmed

Stem Diameter

0.8m

Branch Spread

N – 8m

E – 8m

S – 8m

W – 8m

Height of Crown

2m

Age

Middle aged

Physiological Condition

Fair to poor

Structural Condition

Multi stemmed specimen of coppice re-growth from old rotten stump. Evidence of excessive decay at base of main stems indicate that without reduction this specimen is liable to failure.

Prel. Man. Recommendations

Undertake 30% overall crown reduction. Monitor for stability.

Est. Remaining Contribution

10-20

Category

C

T60	Sycamore (<i>Acer pseudoplatanus</i>)
Height	16m
Single/Multi stemmed	Single stem
Stem Diameter	0.37m
Branch Spread	N – 1m E – 3m S – 4m W – 3m
Height of Crown	6m
Age	Middle aged
Physiological Condition	Fair to poor
Structural Condition	Tree of variable form with low stem diameter to height ratio. Main stem heavily colonised by ivy thus preventing full inspection.
Prel. Man. Recommendations	Sever ivy at base. Monitor for stability.
Est. Remaining Contribution	10-20
Category	C
T61	Goat Willow (<i>Salix caprea</i>)
Height	10m
Single/Multi stemmed	Multi stemmed
Stem Diameter	0.65m
Branch Spread	N – 6m E – 3m S – 2m W – 2m
Height of Crown	3m
Age	Mature
Physiological Condition	Poor
Structural Condition	Tree of poor form that has already partially collapsed. This specimen is at risk of total failure.
Prel. Man. Recommendations	Remove
Est. Remaining Contribution	<10
Category	U
T62	Oak (<i>Quercus robur</i>)
Height	15m
Single/Multi stemmed	Single stem
Stem Diameter	0.8m
Branch Spread	N – 12m E – 6m S – 4m W – 8m
Height of Crown	3m
Age	Mature
Physiological Condition	Fair to poor
Structural Condition	Tree of variable form with evidence of some basal decay. Evidence of severe previous storm damage which has led to commencement of decay within major limbs.
Prel. Man. Recommendations	Undertake 30% overall crown reduction. Monitor for health.
Est. Remaining Contribution	20-40
Category	C

T63	Ash (<i>Fraxinus excelsior</i>)
Height	18m
Single/Multi stemmed	Single stem
Stem Diameter	0.9m
Branch Spread	N – 8m E – 7m S – 5m W – 7m
Height of Crown	6m
Age	Mature
Physiological Condition	Poor
Structural Condition	Tree of variable form with evidence of severe basal decay. This specimen is at risk of failure.
Prel. Man. Recommendations	Remove
Est. Remaining Contribution	<10
Category	U

T64	Ash (<i>Fraxinus excelsior</i>)
Height	18m
Single/Multi stemmed	Single stem
Stem Diameter	0.9m
Branch Spread	N – 10m E – 8m S – 5m W – 4m
Height of Crown	5m
Age	Mature
Physiological Condition	Fair to poor
Structural Condition	Tree of variable form that has previously been heavily reduced leading to commencement of decay within some major limbs
Prel. Man. Recommendations	Undertake 30% overall crown reduction. Monitor for stability.
Est. Remaining Contribution	20-40
Category	C

Recommendations for Tree Protection during Development

Due to the high risk to established trees we would recommend the installation of protective fencing prior to commencement of **any** works on site in accordance with BS 5837:2012 “Trees in relation to Construction”. Trees should be protected using scaffold frame supporting weld mesh panel fencing sited on the edge of the Root Protection Area as defined in BS5837:2012. These fenced areas should not be used for the storage of any plant machinery or materials and personnel should be excluded at all times; these fences should remain in situ until after final landscaping has been carried out, removed by hand with great care to prevent compaction or root damage to established trees. The services of a suitably qualified arborist should be sought **prior** to the commencement of each stage.

Figure 2 Default specification for protective barrier

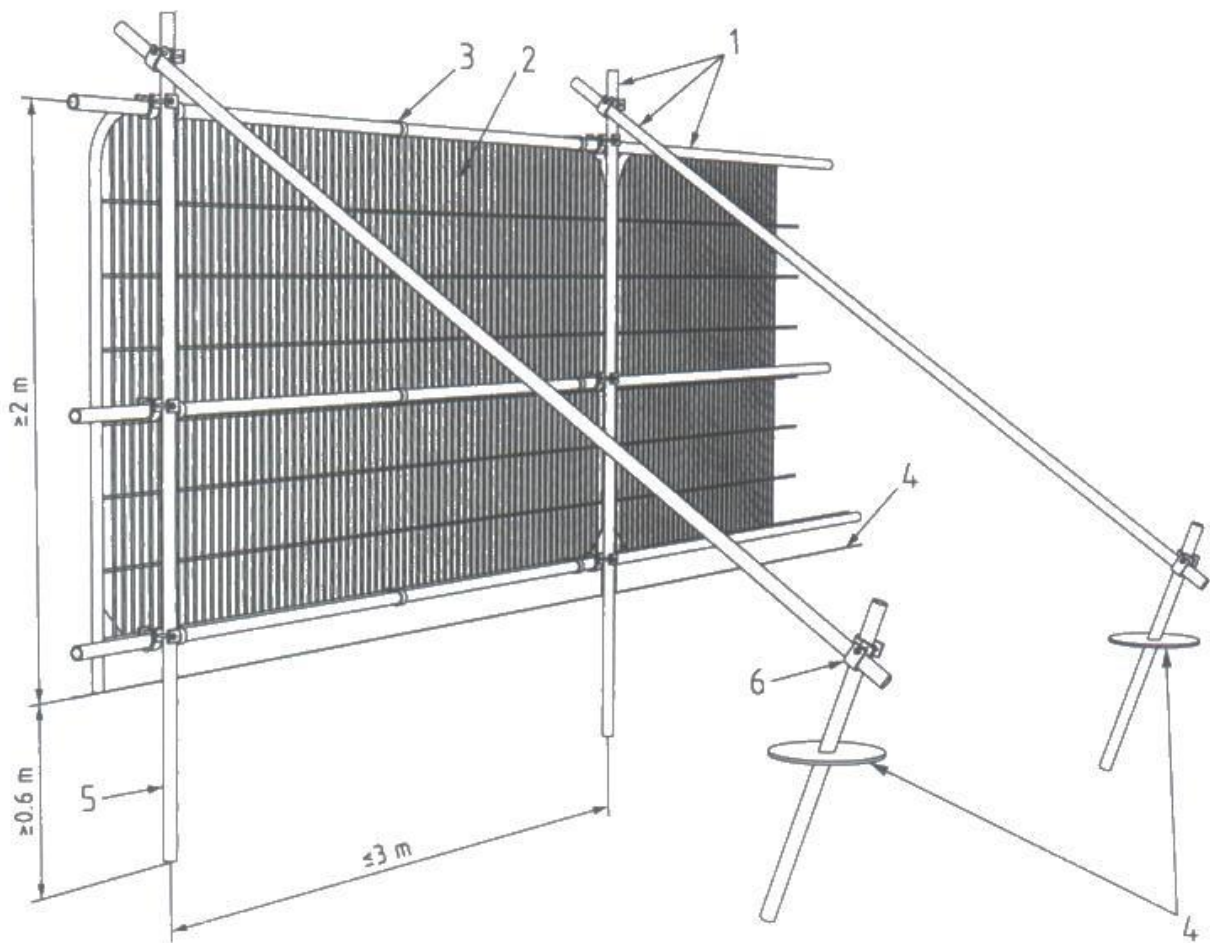

Key

- 1 Standard scaffold poles
- 2 Heavy gauge 2 m tall galvanized tube and welded mesh infill panels
- 3 Panels secured to uprights and cross-members with wire ties
- 4 Ground level
- 5 Uprights driven into the ground until secure (minimum depth 0.6 m)
- 6 Standard scaffold clamps

Northcliff Lodge, Penarth

Tree Constraints Plan



Tree Constraints Plan

- Root Protection Area
- Tree Category
- Tree Number
- Canopy Spread

Category A Trees ●
Category B Trees ●
Category C Trees ●
Category U Trees ●

Scale 1:700 @A3
06/2015

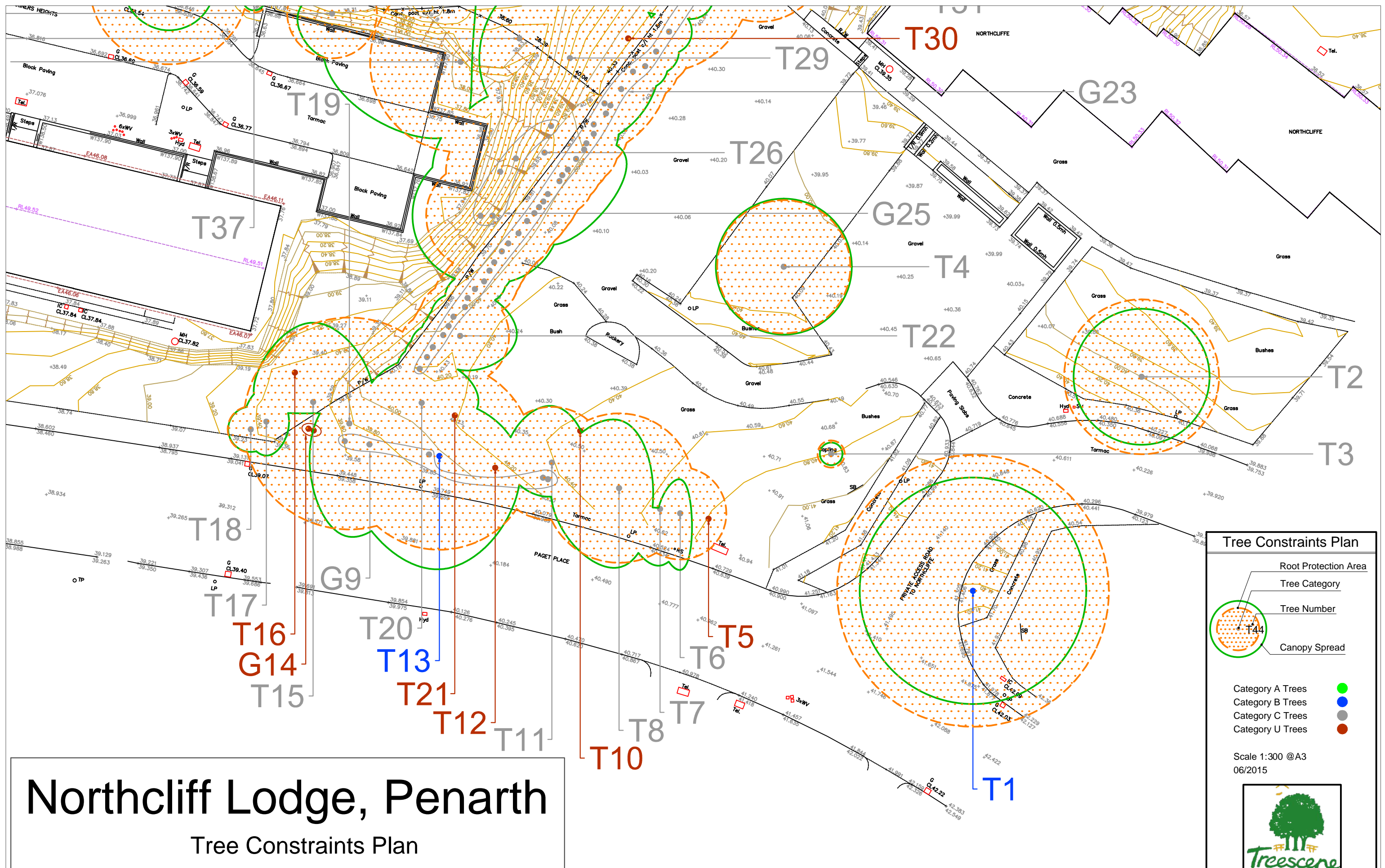

Northcliff Lodge, Penarth

Tree Constraints Plan

Tree Constraints Plan

- Root Protection Area
- Tree Category
- Tree Number
- Canopy Spread

Category A Trees ●
 Category B Trees ●
 Category C Trees ●
 Category U Trees ●

Scale 1:300 @A3
06/2015

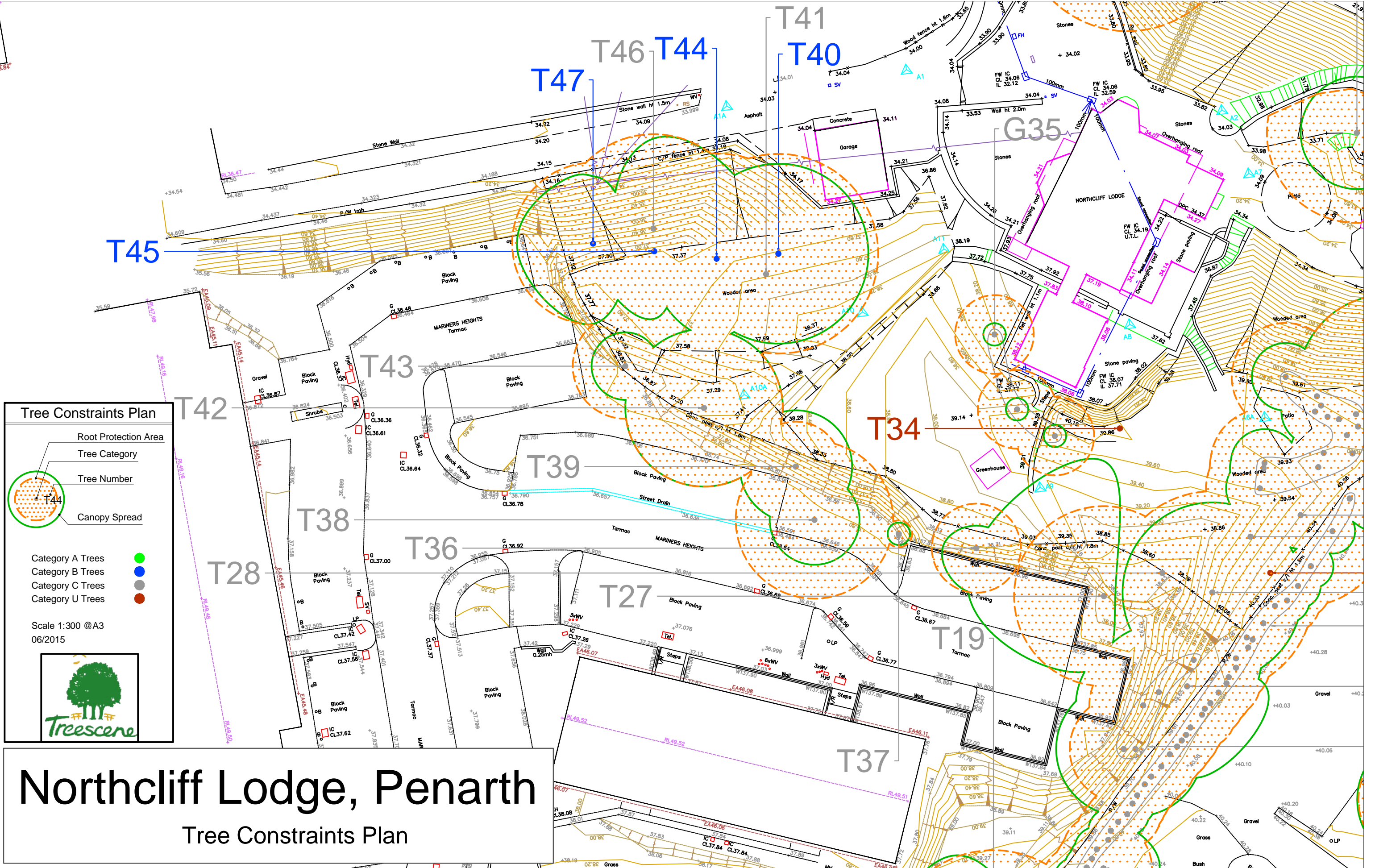

Tree Constraints Plan

- Root Protection Area
- Tree Category
- Tree Number
- Canopy Spread

Category A Trees ●
 Category B Trees ●
 Category C Trees ●
 Category U Trees ●

Scale 1:300 @A3
 06/2015

Northcliff Lodge, Penarth

Tree Constraints Plan

Northcliff Lodge, Penarth

Tree Constraints Plan

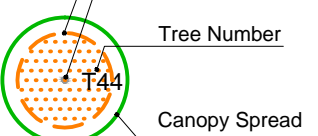

Tree Constraints Plan

- Root Protection Area
- Tree Category
- Tree Number
- Canopy Spread

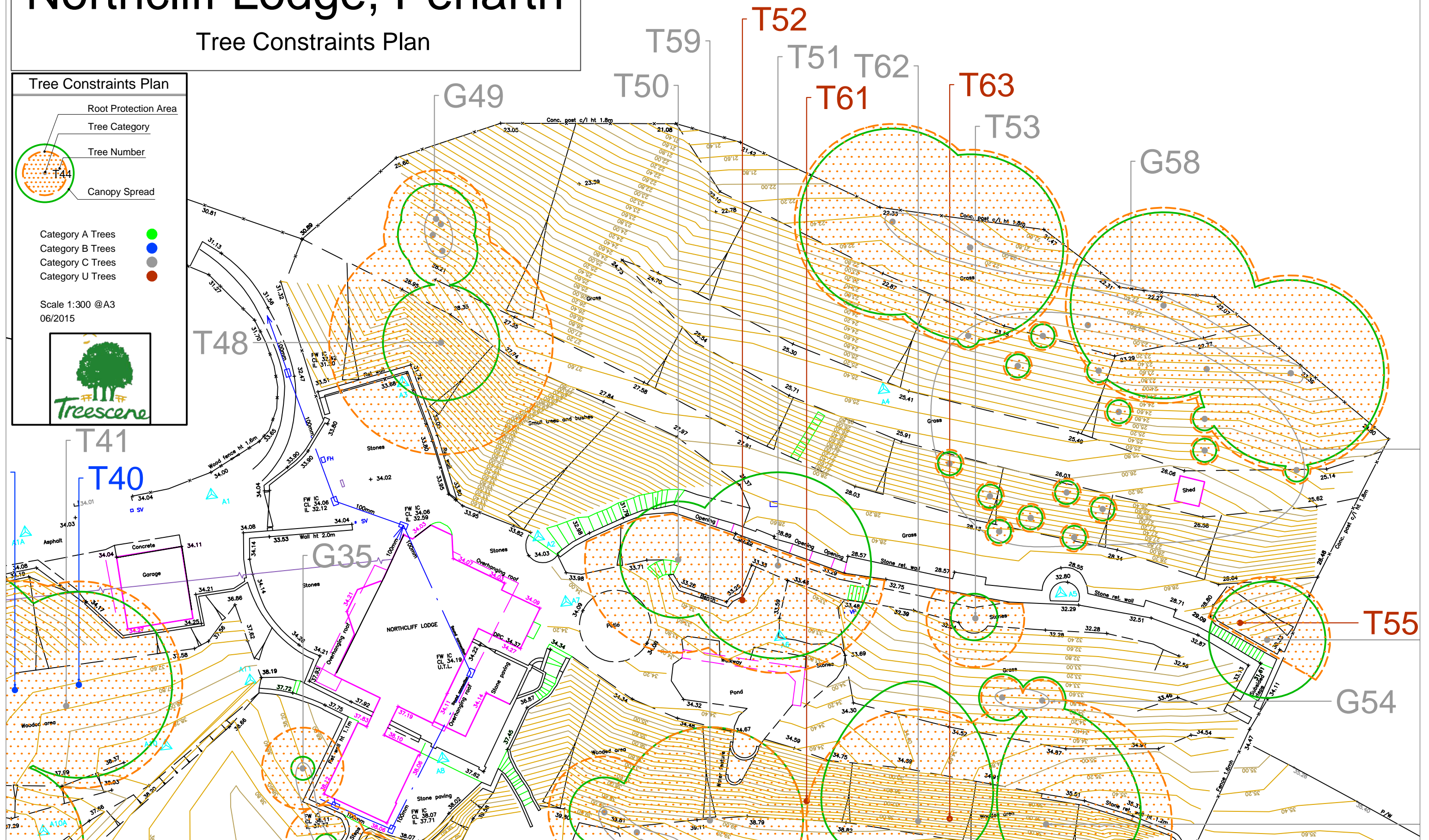

Category A Trees ●
Category B Trees ●
Category C Trees ●
Category U Trees ●

Scale 1:300 @A3
06/2015



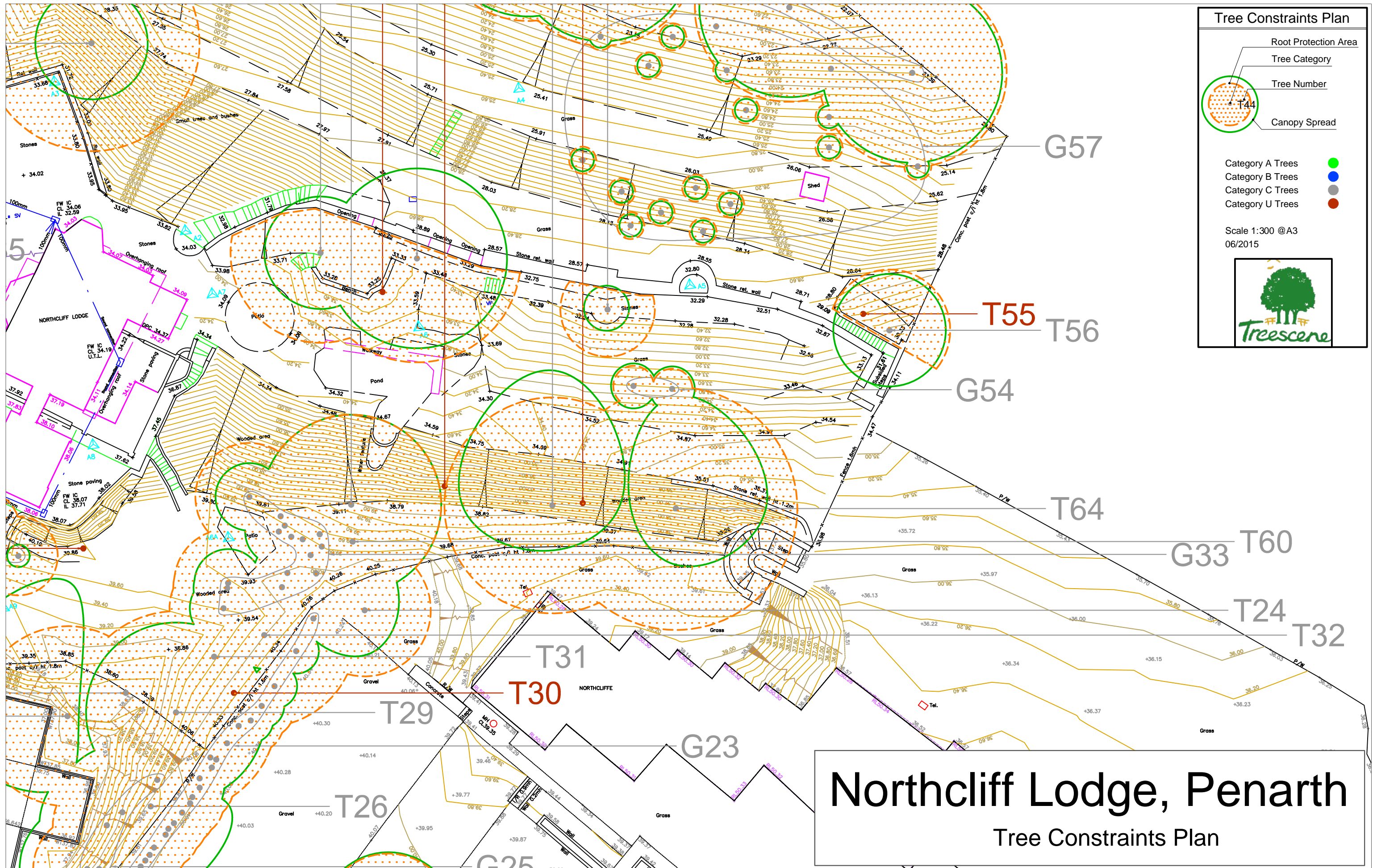

Tree Constraints Plan

- Root Protection Area
- Tree Category
- Tree Number
- Canopy Spread

Category A Trees ●
 Category B Trees ●
 Category C Trees ●
 Category U Trees ●

Scale 1:300 @A3
06/2015

Northcliff Lodge, Penarth
Tree Constraints Plan