

THE VALE OF  
GLAMORGAN COUNCIL  
TOWN AND COUNTRY PLANNING ACT 1990  
**APPROVED**  
SUBJECT TO COMPLIANCE WITH CONDITIONS (IF ANY)

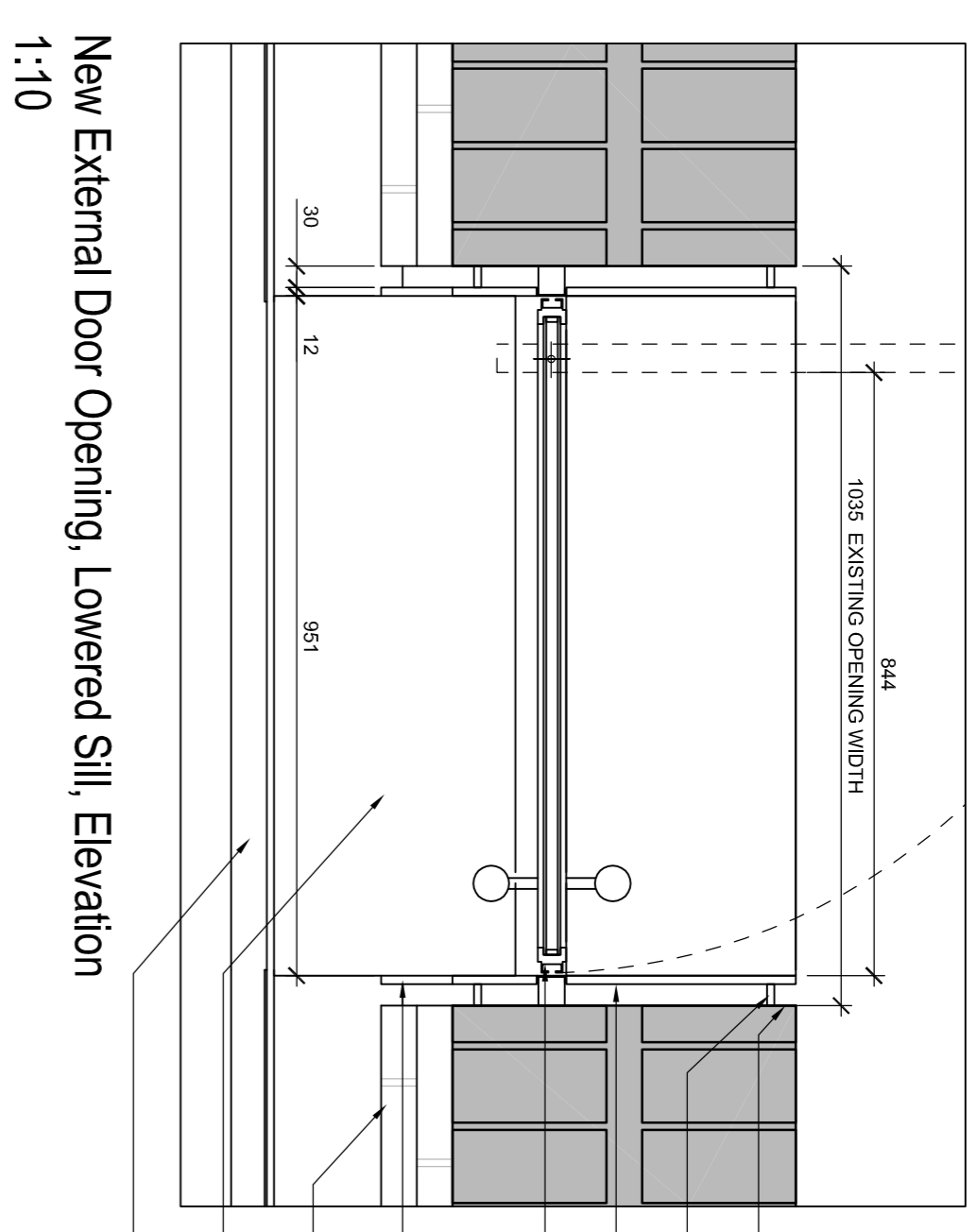

- Cut bricks to lower sill to floor level
- Shadow gap, scuffed trim steel scuffed pieces to match lining
- Reveal lining, 12mm steel plate with bronze epoxy marine paint finish
- Slimline metal framed glazed entrance door
- Reveal lining steps out to conceal cut face of brick step
- Existing base step
- External concrete sill
- Bridge

New External Door Opening, Lowered Sill, Elevation  
1:10

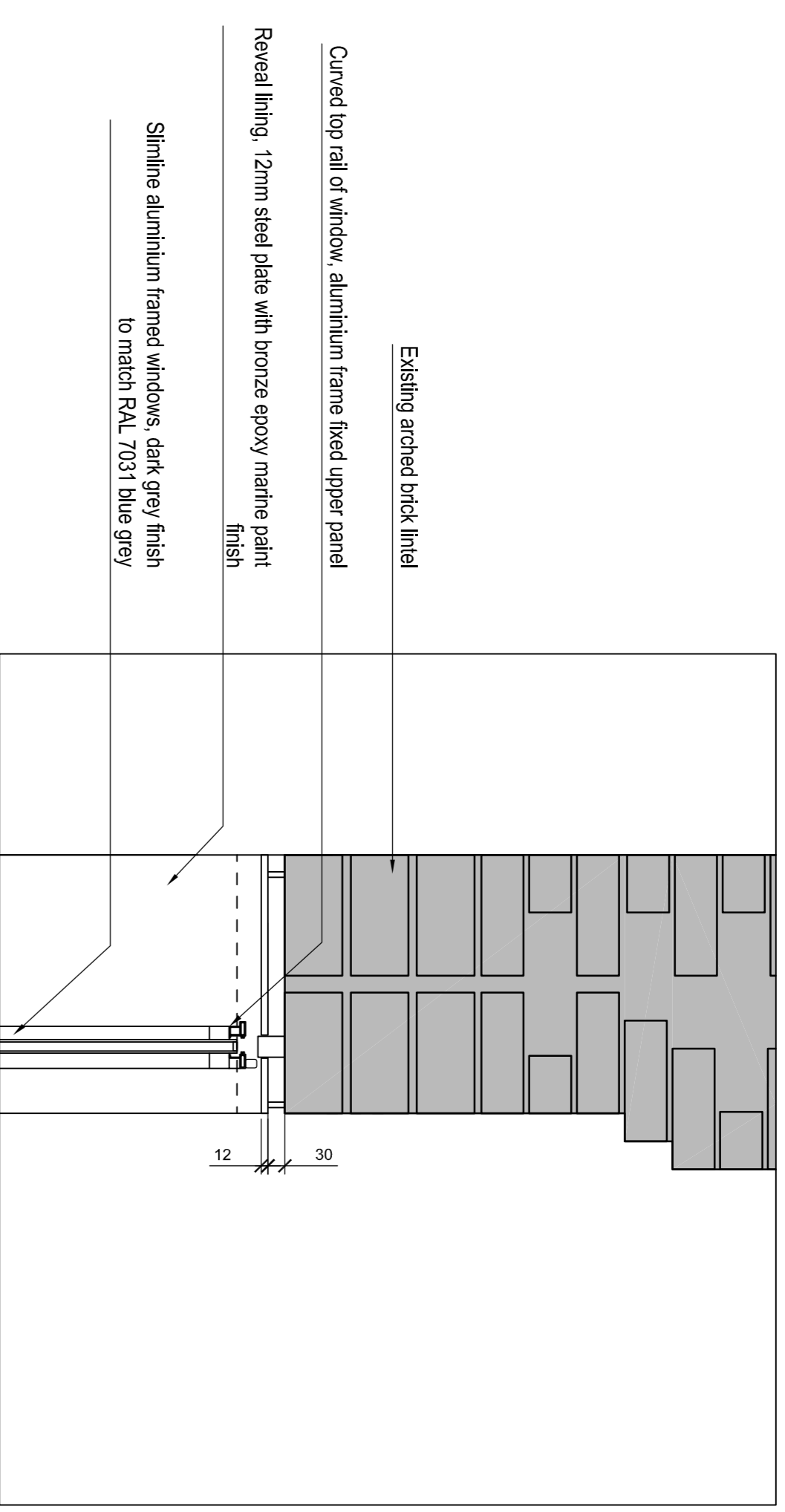
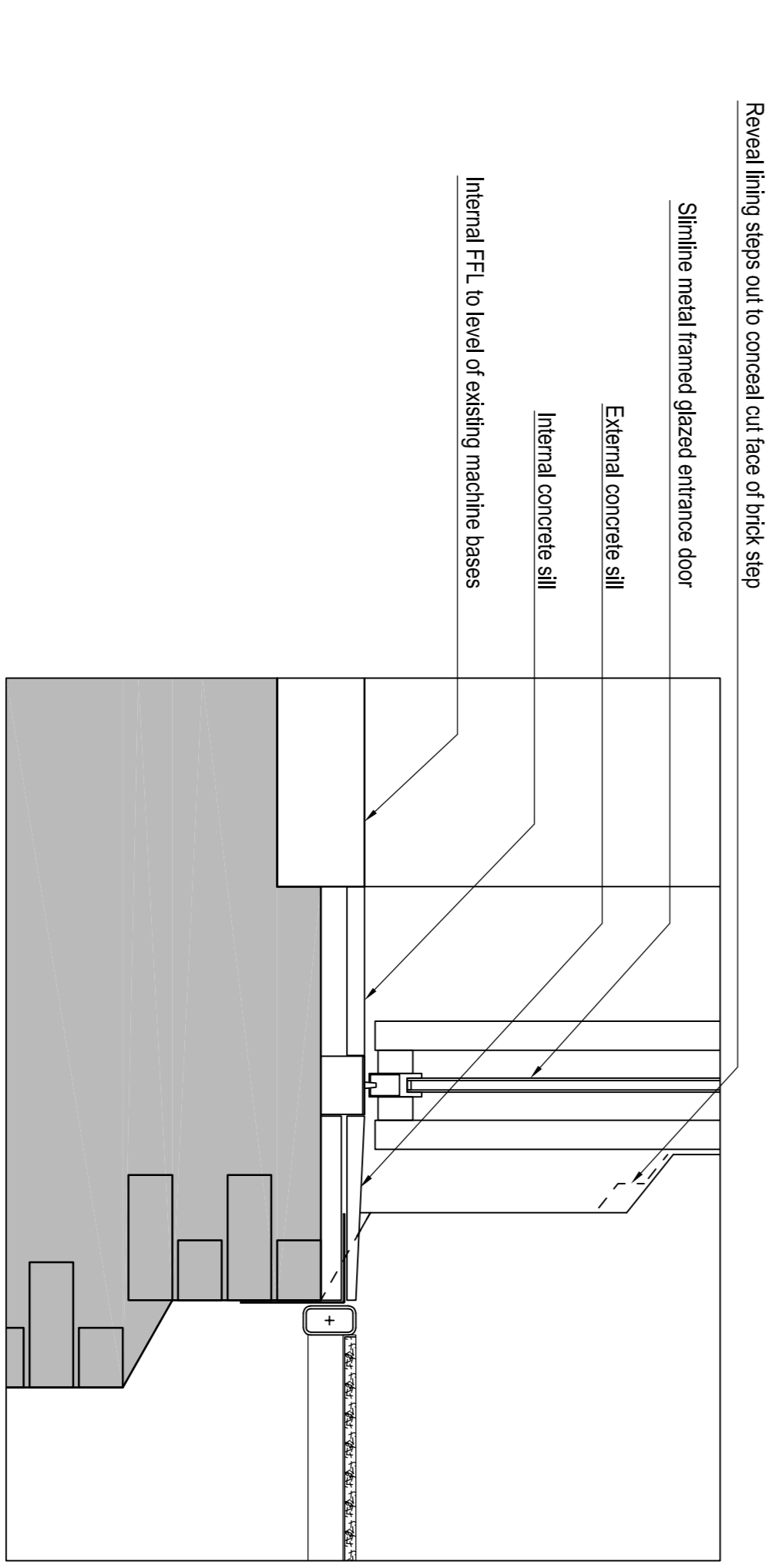
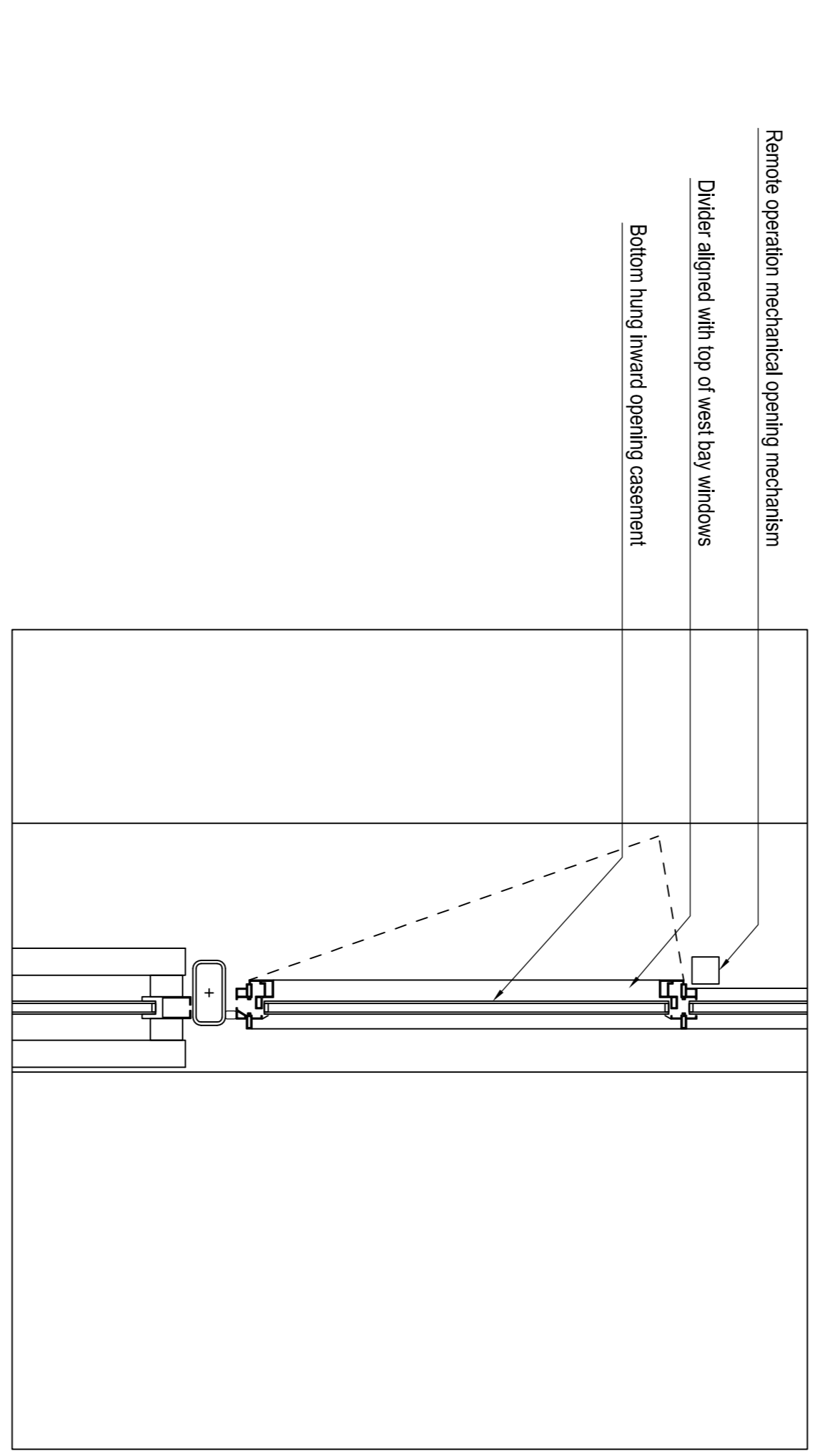

New External Door Opening, Lowered Sill, Section  
1:10

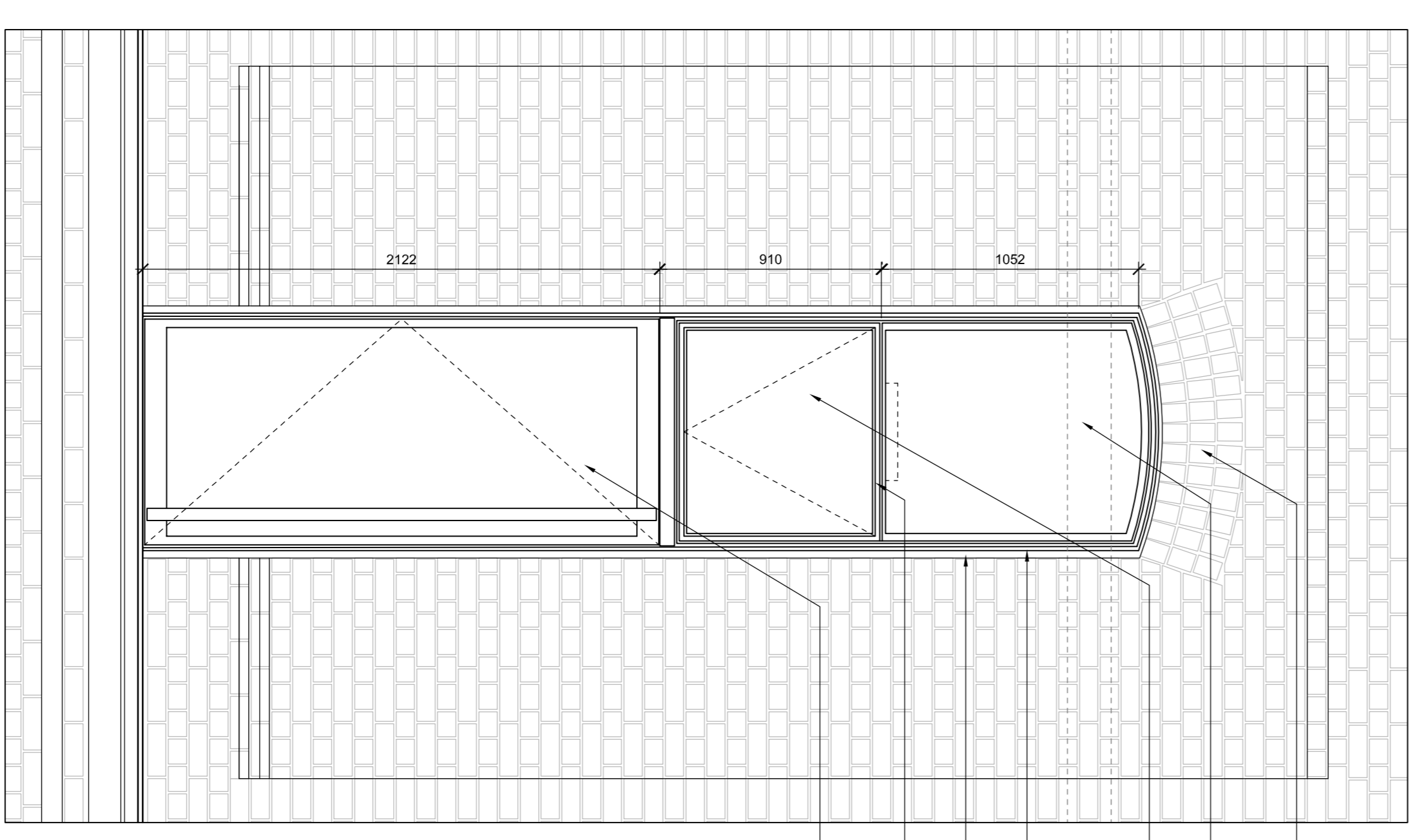

New External Door Opening, Lowered Sill, Elevation  
1:20



3D View

